



Anil Neerukonda Institute of Technology & Sciences (Autonomous)

(Affiliated to AU, Approved by AICTE & Accredited by NBA & NAAC with 'A' Grade)

Sangivalasa-531 162, Bheemunipatnam Mandal, Visakhapatnam District

Phone: 08933-225083/84/87

Fax: 226395

Website: www.anits.edu.in

email: principal@anits.edu.in

GATE MOCK TEST

- A 4-pole induction motor, supplied by a slightly unbalanced three-phase 50 Hz source, is rotating at 1440 rpm. The electrical frequency in Hz of the induced negative sequence current in the rotor is
(A) 100 (B) 98 (C) 52 (D) 48
- When the Newton-Raphson method is applied to solve the equation $f(x) = x^3 + 2x - 1 = 0$, solution at the end of the first iteration with the initial guess value as $x_0 = 1.2$ is
(A) -0.82 (B) 0.49 (C) 0.705 (D) 1.69
- What is the chance that a leap year, selected at random, will contain 53 Saturdays?
(A) $2/7$ (B) $3/7$ (C) $1/7$ (D) $5/7$
- A car travels 8 km in the first quarter of an hour, 6 km in the second quarter and 16 km in the third quarter. The average speed of the car in km per hour over the entire journey is
(A) 30 (B) 36 (C) 40 (D) 24
- The impulse response of a continuous time system is given by $h(t) = \delta(t - 1) + \delta(t - 3)$. The value of the step response at $t = 2$ is
(A) 0 (B) 1 (C) 2 (D) 3
- For a power system network with n nodes, Z_{33} of its bus impedance matrix is $j0.5$ per unit. The voltage at node 3 is $1.3 \angle -10^\circ$ per unit. If a capacitor having reactance of $-j3.5$ per unit is now added to the network between node 3 and the reference node, the current drawn by the capacitor per unit is
(A) $0.325 \angle -100^\circ$ (B) $0.325 \angle 80^\circ$ (C) $0.371 \angle -100^\circ$ (D) $0.433 \angle 80^\circ$
- Leakage flux in an induction motor is
(A) flux that leaks through the machine
(B) flux that links both stator and rotor windings
(C) flux that links none of the windings
(D) flux that links the stator winding or the rotor winding but not both.
- A band-limited signal with a maximum frequency of 5 kHz is to be sampled. According to the

sampling theorem, the sampling frequency in kHz which is not valid is

- (A) 5 (B) 12 (C) 15 (D) 20

9. The angle δ in the swing equation of a synchronous generator is the

- A) angle between stator voltage and current.
B) angular displacement of the rotor with respect to the stator.
C) angular displacement of the stator mmf with respect to a synchronously rotating axis.
D) angular displacement of an axis fixed to the rotor with respect to a synchronously rotating axis.

10. A bulb in a staircase has two switches, one switch being at the ground floor and the other one at the first floor. The bulb can be turned ON and also can be turned OFF by any one of the switches irrespective of the state of the other switch. The logic of switching of the bulb resembles

- (A) an AND gate (B) an OR gate (C) an XOR gate (D) a NAND gate

11. A single-phase load is supplied by a single-phase voltage source. If the current flowing from the load to the source is $10\angle -150^\circ$ A and if the voltage at the load terminals is $100\angle 60^\circ$ V, then the

- A) load absorbs real power and delivers reactive power.
B) load absorbs real power and absorbs reactive power.
C) load delivers real power and delivers reactive power.
D) load delivers real power and absorbs reactive power.

12. The set of values of p for which the roots of the equation $3x^2 + 2x + p(p-1) = 0$ are of opposite sign is

- (A) $(-\infty, 0)$ (B) $(0, 1)$ (C) $(1, \infty)$ (D) $(0, \infty)$

13. Complete the sentence:

Dare _____ mistakes.

- (A) commit (B) to commit (C) committed (D) committing

In the figure shown below, the chopper feeds a resistive load from a battery source. MOSFET Q is switched at 250 kHz, with a duty ratio of 0.4. All elements of the circuit are assumed to be ideal.

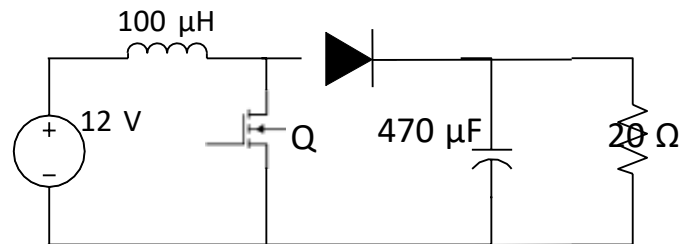

14. The average source current in Amps in steady-state is (A) $3/2$ (B) $5/3$ (C) $5/2$ (D) $15/4$

15. The PEAK-TO-PEAK source current ripple in Amps is (A) 0.96 (B) 0.144 (C) 0.192 (D) 0.288

16. Choose the grammatically **CORRECT** sentence:

- (B) Two and two add four.
- (C) Two and two become four.
- (D) Two and two are four.
- (E) Two and two make four.

The Voltage Source Inverter (VSI) shown in the figure below is switched to provide a 50 Hz, square-waveac output voltage (v_o) across an R-L load. Reference polarity of v_o and reference direction of the output current i_o are indicated in the figure. It is given that $R = 3 \Omega$, $L = 9.55 \text{ mH}$.

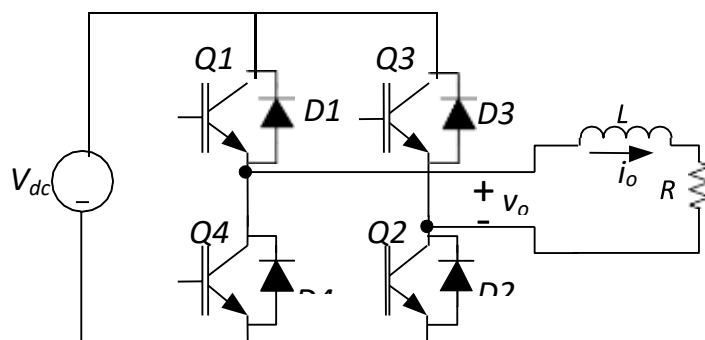

17. In the interval when $v_0 < 0$ and $i_0 > 0$ the pair of devices which conducts the load current is

- (A) Q1, Q2 (B) Q3, Q4 (C) D1, D2 (D) D3, D4

18. Appropriate transition i.e., Zero Voltage Switching (ZVS)/Zero Current Switching (ZCS) of the IGBTs during turn-on/turn-off is

- (A) ZVS during turn-off (B) ZVS during turn-on
 (C) ZCS during turn-off (D) ZCS during turn-on

19. The impulse response of a continuous time system is given by $h(t) = \delta(t - 1) + \delta(t - 3)$. The value of the step response at $t = 2$ is

- (A) 0 (B) 1 (C) 2 (D) 3

20. In the circuit shown below, the knee current of the ideal Zener diode is 10 mA. To maintain 5 V across R_L , the minimum value of R_L in Ω and the minimum power rating of the Zener diode in mW respectively are

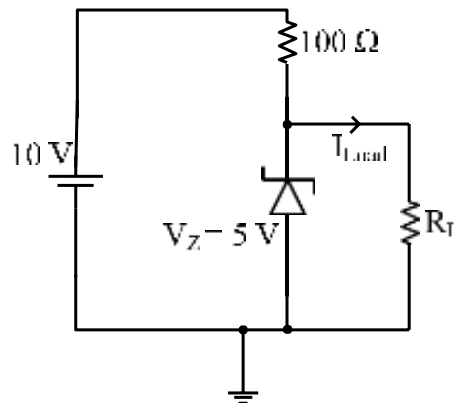

- (A) 125 and 125 (B) 125 and 250 (C) 250 and 125 (D) 250 and 250

